

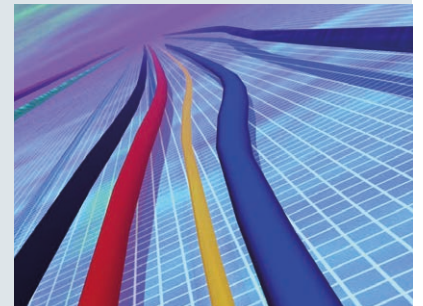

Surge protection for Local Operating Networks (LONs)

White Paper



Contents

Transceivers with their transmission rates and maximum network expansion

Capacitances of transceivers in FTT/LPT networks

Capacitances of surge protective devices

Surges caused by induction loops

Surge protective devices for an FTT/LPT in a combination topology extending beyond buildings

Surge protection for Local Operating Networks (LONs)

White Paper

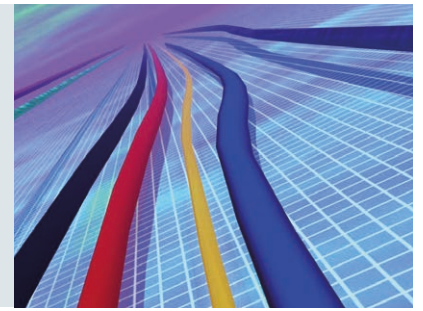

Medium	Transceiver	Transmission	Network expansion	Node → Node	Node supply
Two-wire	TP/XF-78	78 kbit/s	1400 m bus / line		Separately
Two-wire	TP/XF-1250	1250 kbit/s	130 m bus / line		Separately
Two-wire	FTT10-A	78 kbit/s	2700 m bus / line 500 m open structure	J-Y(ST)Y 2x2x0.8 320 m open structure	Separately
Two-wire	LPT-10	78 kbit/s	2200 m bus / line 500 m open structure	J-Y(ST)Y 2x2x0.8 320 m open structure	Via bus cable

Table 1 Transceivers (most common transceivers are printed in bold) with their transmission rates and maximum network expansion

The LonWorks technology allows to implement distributed automation systems. In this context, intelligent nodes communicate via the LonTalkProtocol®. The neuron chip (3120, 3150 and various enhancements), which accesses a transmission medium via a transceiver and features an I/O circuit for connecting, for example switches, relays, analogue outputs, analogue value measurement systems, is the core of a node (Figure 1).

Transmission media

In addition to the two-wire connection described below, 230 V, optical fibre cable, coaxial cable, LAN and radio transmission is possible.

Two-wire bus cable used as transmission medium

The transceivers for a two-wire bus cable (e.g. J-Y(ST)Y 2x2x0.8) have different transmission rates (kbit/s) and a different maximum network expansion (cable length in metres) (Table 1).

Since the two-wire bus cable can be placed in free space, the devices in the LON building installation are mainly equipped with FTTs (Free Topology Transceivers) and LPT (Link Power

Transceivers) (LPTs are compatible with FTTs at the same bus).

The transceivers in FTT /LPT networks have the core/core and core/earth capacitances shown in Table 2. If surge protective devices are installed, their capacitances (core/core and core/earth) must also be considered since the maximum number of transceivers to be used is reduced accordingly (Table 3).

Surges caused by induction loops

When routing the cables, it must be observed that no induction loops are formed. Therefore, the bus and low-voltage cables leading to the bus devices must be routed in close

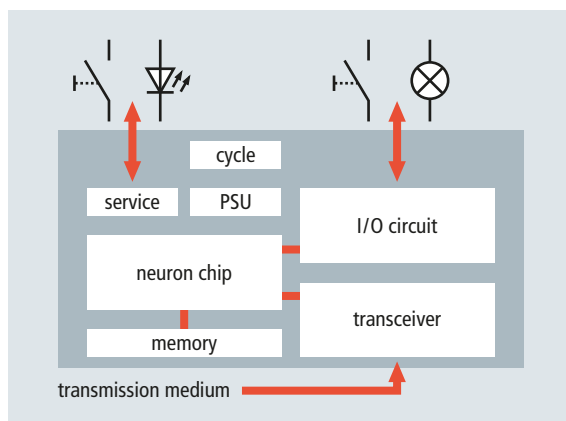

Figure 1 Structure of a LonWorks node with neuron chip, transceiver and I/O circuit

Transceiver	Capacitance	
	Core / core	Core / earth
FTT10-A	300 pF	10 max. 20 pF
LPT-10	150 pF	10 pF

Table 2 Capacitances of transceivers in FTT /LPT networks

Surge protective device	Capacitance	
	Core / core	Core / earth
BXT ML2 BD S 48	700 pF	25 pF

Table 3 Capacitances of surge protective devices

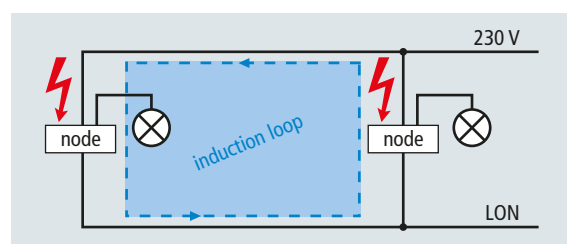

Figure 2 Induction loop caused by two nodes

Surge protection for Local Operating Networks (LONs)

White Paper

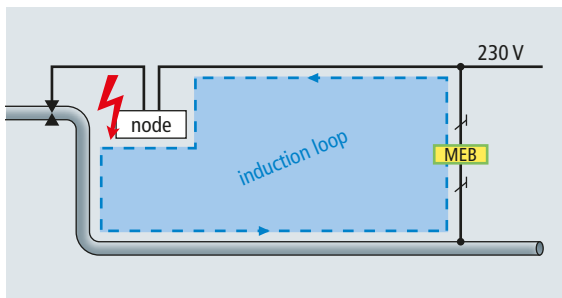
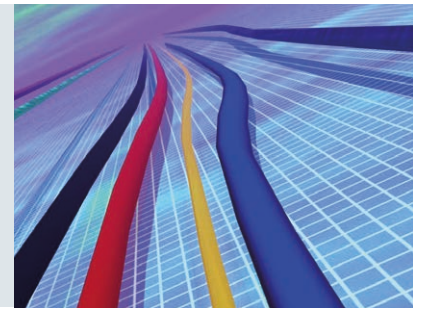

Figure 3 Induction loop caused by a magnetic valve attached to a metallic pipe

proximity to one another (Figure 2). If a J-Y(ST)Y cable has a dielectric strength of 2.5 kV, this cable can be connected

in parallel with a low-voltage cable. However, a distance of 10 mm must be kept after removing the J-Y(ST)Y cable sheath. Loops are also formed if a node is attached to a metallic construction/pipe which is connected to the main earthing bus-bar (Figure 3). Also in this case, it is advisable to route the cables as close as possible to the construction/pipe.

Surge protection in case of a combination topology

If the inputs/outputs connected to the node are located in close proximity to the node, surge protective devices are not required.

Figure 4 shows surge protective devices for LPTs which are supplied by means of a two-wire bus cable. Figure 5 shows surge protective devices for directly supplied FTTs (typically 24 V d.c.) in case of long connecting cables of power supply units.

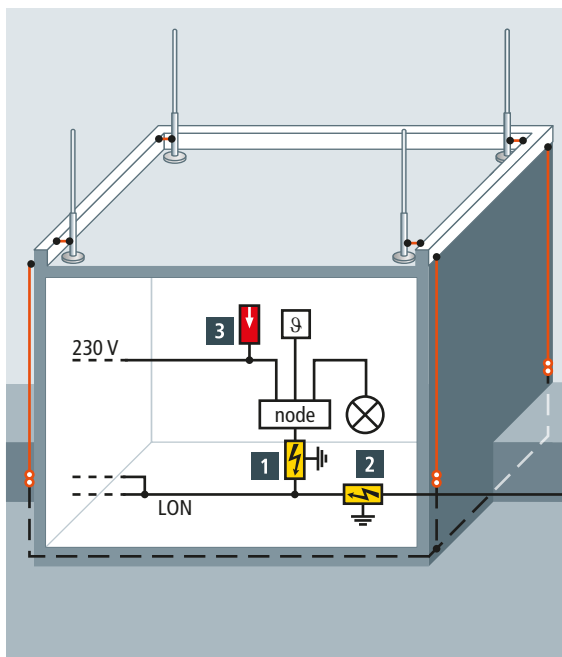

No.	Surge protective device	Part No.
1	BXT ML2 BD S 48 + BXT BAS	920 245 920 300
2	see 1 (lightning equipotential bonding)	
3	DR M 2P 255	953 200

Figure 4 Surge protective devices for an LPT in a combination topology extending beyond buildings

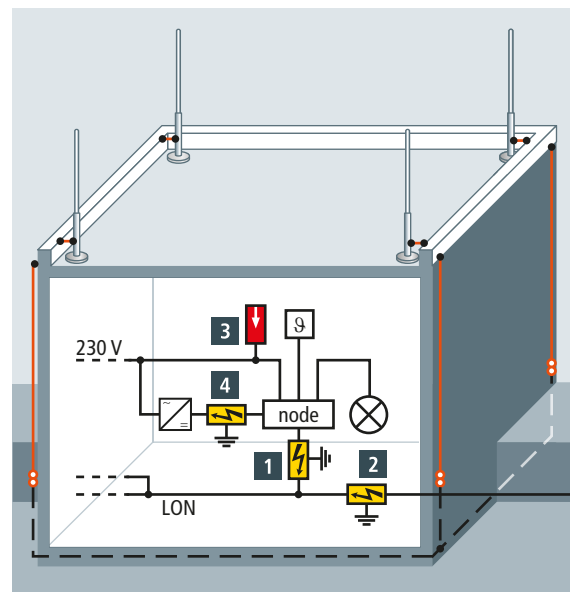

No.	Surge protective device	Part No.
1	BXT ML2 BD S 48 + BXT BAS	920 245 920 300
2	see 1 (lightning equipotential bonding)	
3	DR M 2P 255	953 200
4	BXT ML2 BE S 24 + BXT BAS	920 224 920 300

Figure 5 Surge protective devices for an FTT in a combination topology extending beyond buildings

DEHNrail

DR M 2P 255 (953 200)

- Two-pole surge arrester consisting of a base element and plug-in protection module
- High discharge capacity due to heavy-duty zinc oxide varistor/spark gap combination
- Energy coordination with other arresters of the Red/Line product family



Figure without obligation

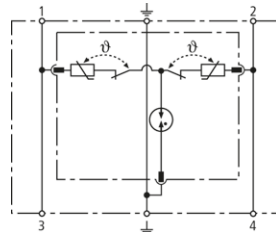

Basic circuit diagram DR M 2P 255

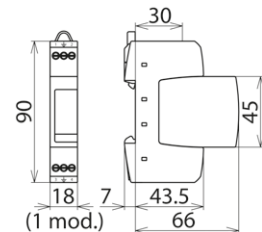

Dimension drawing DR M 2P 255

Two-pole surge arrester consisting of a base part and plug-in protection module

Type	DR M 2P 255
Part No.	953 200
SPD according to EN 61643-11	Type 3
SPD according to IEC 61643-1/-11	Class III
Nominal a.c. voltage (U_N)	230 V
Max. continuous operating a.c. voltage (U_C)	255 V
Max. continuous operating d.c. voltage (U_C)	255 V
Nominal load current a.c. (I_L)	25 A
Nominal discharge current (8/20 μ s) (I_n)	3 kA
Total discharge current (8/20 μ s) [L+N-PE] (I_{total})	5 kA
Combined impulse (U_{OC})	6 kV
Combined impulse [L+N-PE] ($U_{OC total}$)	10 kV
Voltage protection level [L-N] (U_P)	≤ 1250 V
Voltage protection level [L/N-PE] (U_P)	≤ 1500 V
Response time [L-N] (t_A)	≤ 25 ns
Response time [L/N-PE] (t_A)	≤ 100 ns
Max. mains-side overcurrent protection	25 A gL/gG or B 25 A
Short-circuit withstand capability for mains-side overcurrent protection with 25 A gL/gG	6 kA _{rms}
Temporary overvoltage (TOV) [L-N] (U_T)	335 V / 5 sec.
Temporary overvoltage (TOV) [L/N-PE] (U_T)	400 V / 5 sec.
Temporary overvoltage (TOV) [L+N-PE] (U_T)	1200 V + U_{CS} / 200 ms
TOV characteristic [L-N]	withstand
TOV characteristic [L/N-PE]	withstand
TOV characteristic [L+N-PE]	withstand
Operating temperature range (T_U)	-40°C...+80°C
Operating state/fault indication	green / red
Number of ports	1
Cross-sectional area (min.)	0.5 mm ² solid/flexible
Cross-sectional area (max.)	4 mm ² solid/2.5 mm ² flexible
For mounting on	35 mm DIN rails acc. to EN 60715
Enclosure material	thermoplastic, red, UL 94 V-0
Place of installation	indoor installation
Degree of protection	IP 20
Capacity	1 module(s), DIN 43880
Approvals	KEMA, VDE, UL, VdS, CSA
Weight	81 g
Customs tariff number	85363030
GTIN	4013364108301
PU	1 pc(s)

BLITZDUCTOR XT

BXT ML2 BE S 24 (920 224)

- LifeCheck SPD monitoring function
- Optimal protection of two single lines and the cable shield
- For use in conformity with the lightning protection zone concept at the boundaries from $0_A -2$ and higher



Figure without obligation

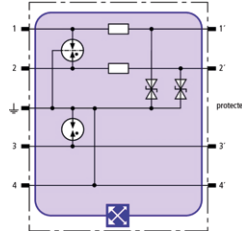

Basic circuit diagram BXT ML2 BE S 24

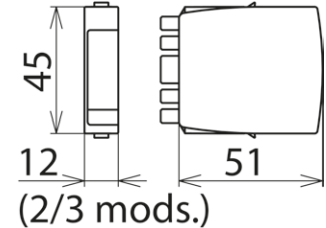

Dimension drawing BXT ML2 BE S 24

Space-saving combined lightning current and surge arrester module with LifeCheck feature for protecting two single lines sharing a common reference potential as well as unbalanced interfaces, with direct or indirect shield earthing. If LifeCheck detects thermal or electrical overload, the arrester has to be replaced. This status is indicated contactlessly by the DEHNrecord LC / SCM / MCM reader.

Type	BXT ML2 BE S 24
Part No.	920 224
SPD monitoring system	LifeCheck
SPD class	TYPE 1 P _A
Nominal voltage (U_N)	24 V
Max. continuous operating d.c. voltage (U_C)	33 V
Max. continuous operating a.c. voltage (U_C)	23.3 V
Nominal current at 45 °C (I_L)	0.75 A
D1 Total lightning impulse current (10/350 μ s) (I_{imp})	9 kA
D1 Lightning impulse current (10/350 μ s) per line (I_{imp})	2.5 kA
C2 Total nominal discharge current (8/20 μ s) (I_n)	20 kA
C2 Nominal discharge current (8/20 μ s) per line (I_n)	10 kA
Voltage protection level line-line for I_{imp} D1 (U_p)	≤ 102 V
Voltage protection level line-PG for I_{imp} D1 (U_p)	≤ 66 V
Voltage protection level line-line at 1 kV/ μ s C3 (U_p)	≤ 90 V
Voltage protection level line-PG at 1 kV/ μ s C3 (U_p)	≤ 45 V
Series resistance per line	1.8 ohm(s)
Cut-off frequency line-PG (f_c)	6.8 MHz
Capacitance line-line (C)	≤ 0.5 nF
Capacitance line-PG (C)	≤ 1.0 nF
Operating temperature range (T_U)	-40 °C ... +80 °C
Degree of protection (plugged-in)	IP 20
Pluggable into	BXT BAS / BSP BAS 4 base part
Earthing via	BXT BAS / BSP BAS 4 base part
Enclosure material	polyamide PA 6.6
Colour	yellow
Test standards	IEC 61643-21 / EN 61643-21, UL 497B
SIL classification	up to SIL3 ^{*)}
ATEX approvals	DEKRA 11ATEX0089 X: II 3 G Ex nA IIC T4 Gc
IECEx approvals	DEK 11.0032X: Ex nA IIC T4 Gc
CSA & USA Hazloc approvals (1)	2516389: Class I Div. 2 GP A, B, C, D T4
CSA & USA Hazloc approvals (2)	2516389: Class I Zone 2, AEx nA IIC T4
Approvals	CSA, GOST, VdS
Weight	37 g
Customs tariff number	85363010
GTIN	4013364117785
PU	1 pc(s)

^{*)}For more detailed information, please visit www.dehn-international.com.

BLITZDUCTOR XT

BXT ML2 BD S 48 (920 245)

- LifeCheck SPD monitoring function
- Optimal protection of one pair and the cable shield
- For installation in conformity with the lightning protection zone concept at the boundaries from $0_A -2$ and higher



Figure without obligation

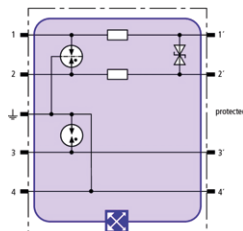

Basic circuit diagram BXT ML2 BD S 24 48

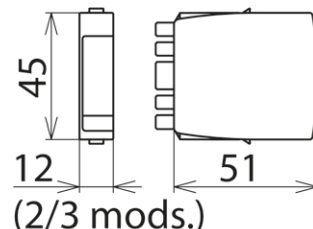

Dimension drawing BXT ML2 BD S 48

Space-saving combined lightning current and surge arrester module with LifeCheck feature for protecting one pair of unearthed balanced interfaces with direct or indirect shield earthing. If LifeCheck detects thermal or electrical overload, the arrester has to be replaced. This status is indicated contactlessly by the DEHNrecord LC / SCM / MCM reader.

Type	BXT ML2 BD S 48
Part No.	920 245
SPD monitoring system	LifeCheck
SPD class	TYPE 1 P1
Nominal voltage (U_N)	48 V
Max. continuous operating d.c. voltage (U_C)	54 V
Max. continuous operating a.c. voltage (U_C)	38.1 V
Nominal current at 45 °C (I_L)	1.0 A
D1 Total lightning impulse current (10/350 μ s) (I_{imp})	9 kA
D1 Lightning impulse current (10/350 μ s) per line (I_{imp})	2.5 kA
C2 Total nominal discharge current (8/20 μ s) (I_n)	20 kA
C2 Nominal discharge current (8/20 μ s) per line (I_n)	10 kA
Voltage protection level line-line for I_{imp} D1 (U_p)	≤ 80 V
Voltage protection level line-PG for I_{imp} D1 (U_p)	≤ 550 V
Voltage protection level line-line at 1 kV/ μ s C3 (U_p)	≤ 70 V
Voltage protection level line-PG at 1 kV/ μ s C3 (U_p)	≤ 550 V
Series resistance per line	1.0 ohm(s)
Cut-off frequency line-line (f_c)	8.7 MHz
Capacitance line-line (C)	≤ 0.7 nF
Capacitance line-PG (C)	≤ 25 pF
Operating temperature range (T_U)	-40 °C ... +80 °C
Degree of protection (plugged-in)	IP 20
Pluggable into	BXT BAS / BSP BAS 4 base part
Earthing via	BXT BAS / BSP BAS 4 base part
Enclosure material	polyamide PA 6.6
Colour	yellow
Test standards	IEC 61643-21 / EN 61643-21
SIL classification	up to SIL3 ^{*)}
ATEX approvals	DEKRA 11ATEX0089 X: II 3 G Ex nA IIC T4 Gc
IECEx approvals	DEK 11.0032X: Ex nA IIC T4 Gc
CSA & USA Hazloc approvals (1)	2516389: Class I Div. 2 GP A, B, C, D T4
CSA & USA Hazloc approvals (2)	2516389: Class I Zone 2, AEx nA IIC T4
Approvals	CSA, GOST, VdS
Weight	36 g
Customs tariff number	85363010
GTIN	4013364118386
PU	1 pc(s)

^{*)} For more detailed information, please visit www.dehn-international.com.

BLITZDUCTOR XT

BXT BAS (920 300)

- Vierpolig und universell für alle Ableiter-Module BSP und BXT / BXTU
- Ohne Signaltrennung bei gezogenem Schutzmodul
- Wartungsneutraler Aufbau ohne Schutzelemente



Abbildung unverbindlich

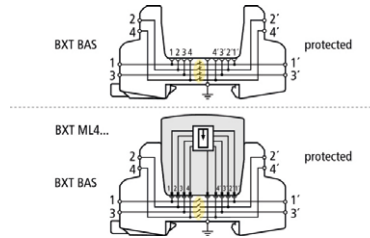

Prinzipialschaltbild mit und ohne gestecktem Modul

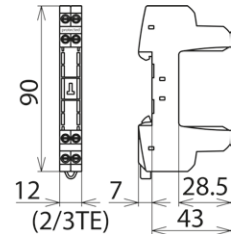

Maßbild BXT BAS

BLITZDUCTOR XT-Basisteil als sehr platzsparende, vierpolige, universelle Durchgangsklemme zur Aufnahme eines Ableiter-Moduls, ohne Signaltrennung bei gezogenem Schutzmodul. Die sichere Erdung des Ableiter-Moduls wird über den Hutschiene-Tragfuß mittels einer Schnappbefestigung hergestellt. Da sich keinerlei Bauelemente der Schutzschaltung im Basisteil befinden, beschränken sich Wartungsarbeiten auf die Schutzmodule.

Typ Art.-Nr.	BXT BAS 920 300
Betriebstemperaturbereich (T _U)	-40 °C ... +80 °C
Schutzart	IP 20
Montage auf	35 mm Hutschiene nach EN 60715
Anschluss Eingang / Ausgang	Schraube / Schraube
Signaltrennung	nein
Anschlussquerschnitt eindrätig	0,08-4 mm ²
Anschlussquerschnitt feindrätig	0,08-2,5 mm ²
Anzugsdrehmoment (Anschlussklemmen)	0,4 Nm
Erdung über	35 mm Hutschiene nach EN 60715
Gehäusewerkstoff	Polyamid PA 6.6
Farbe	gelb
ATEX-Zulassungen	DEKRA 11ATEX0089 X: II 3 G Ex nA IIC T4 Gc ^{*)}
IECEX-Zulassungen	DEK 11.0032X: Ex nA IIC T4 Gc ^{*)}
Zulassungen	CSA, VdS, UL, GOST
Gewicht	34 g
Zolltarifnummer	85369010
GTIN (EAN)	4013364109179
VPE	1 Stk.

^{*)} nur in Verbindung mit zugelassenem Ableiter-Modul

www.dehn-international.com/partners



**Surge Protection
Lightning Protection
Safety Equipment
DEHN protects.**

DEHN + SÖHNE
GmbH + Co.KG.

Hans-Dehn-Str. 1
Postfach 1640
92306 Neumarkt
Germany

Tel. +49 9181 906-0
Fax +49 9181 906-1100
info@dehn.de
www.dehn-international.com



www.dehn-international.com/partners

Type designations of products mentioned in the white paper being at the same time registered trademarks are not especially marked. So if there is no marking of TM or © this does not mean that the type designation is a free trade name. Neither it can be seen whether patents or utility models and other intellectual and industrial property rights are available. We reserve the right to introduce changes in performance, configuration and technology, dimensions, weights and materials in the course of technical progress. The figures are shown without obligation. Misprints, errors and modifications excepted. Reproduction in any form whatsoever is forbidden without our authorisation.

actiVsense, BLITZDUCTOR, BLITZPLANER, DEHN, DEHN Logo, DEHN schützt, DEHNBloc, DEHNfix, DEHNgrip, DEHNguard, DEHNport, DEHNQUICK, DEHNrapid, DEHNshield, DEHNSnap, DEHNventil, HVI, LifeCheck, Red/Line are protected by German Trade Mark, by Community Trade Mark (EU) and/or in other countries.

Digital Graphic "Representation of cyberspace" by Steve Johnson (<https://www.flickr.com/photos/artbystevejohnson/4607812720/>); Licence: CC BY 2.0 (<https://creativecommons.org/licenses/by/2.0/>)