



Earth-termination system for onshore wind turbines

White Paper



Contents

Standards for earth-termination systems

Earth-termination system

Foundation earth electrodes

Example: earth-termination system of a wind turbine

Recommended products for the earth-termination system

Earth-termination system for onshore wind turbines

White Paper



Standards for earth-termination systems

This document refers to international and German standards. Please note that country-specific standards can differ from German standards. The following standards form the basis for the installation of the earth-termination systems of onshore wind turbines with integrated medium-voltage system:

- ➔ IEC 61400-24 – International standard – Wind turbines Part 24: Lightning protection
- ➔ IEC 60364-5-54 – International standard – Low-voltage electrical installations
- ➔ IEC 61936-1 – International standard – Power installations exceeding 1 kV a.c.
- ➔ IEC 62305-3 – International standard – Protection against lightning Part 3
- ➔ DIN 18014 – Foundation earth electrode

DIN 18014: Foundation earth electrode

The fundamental design of a foundation earth electrode is defined in the German DIN 18014 standard. This DIN standard particularly describes the types of earth electrodes in case of tank seals, e.g. white tank, black tank and perimeter insulation. If a building is equipped with a lightning protection system, the additional requirements in IEC 62305-3 must also be observed.

Foundation earth electrodes are an integral part of the electrical installation (DIN 18014, section 4) and fulfil essential safety functions. Therefore, they must be installed by or under the supervision of an electrician (lightning protection specialist). Foundation earth electrodes must be installed as a closed ring and arranged in the foundations of the exterior walls of the building or in the foundation slab according to DIN 18014, section 5.1.

Earth-termination system

The earth-termination system of a wind turbine has the following tasks:

- ➔ **Protective earthing** with the task of safely connecting electrical equipment to the ground and protecting persons and property in the event of an electrical fault.
- ➔ **Functional earthing** with the task of ensuring safe and trouble-free operation of the electrical and electronic equipment.
- ➔ **Lightning protection earthing** with the task of safely conducting the lightning current from the down conductors to the ground.
- ➔ From the point of view of lightning protection, a single, common earth-termination system for all purposes (e.g. medium-voltage system, low-voltage supply, lightning protection, electromagnetic compatibility, telecommunication

and control systems) is advantageous for wind turbines to fulfil the tasks listed.

The reinforced concrete foundations of wind turbines should primarily be as a foundation earth electrode. They provide a low earth resistance and represent an excellent basis for equipotential bonding.

As a medium-voltage transformer is also installed in the wind turbine, the earth-termination system must be designed according to IEC 61936-1.

Like the lightning protection standard, IEC 61936-1 describes all types of earth electrodes. Foundation earth electrodes are defined as the most effective earth electrodes.

The design of earth-termination systems according to IEC 61936-1 must fulfil four requirements:

- ➔ Mechanical strength and corrosion resistance must be ensured
- ➔ Maximum fault current (calculated) must be coped with from a thermal point of view
- ➔ Damage to objects and equipment must be avoided
- ➔ Persons must be protected from voltage at earth-termination systems that occurs in case of the maximum fault current

Consequently, the following parameters are important for dimensioning the earth-termination system:

- ➔ Composition of the surrounding ground
- ➔ Type of neutral point treatment and the resulting short-circuit currents in case of a fault

In a turbine with different nominal voltages, these requirements must be fulfilled for every high-voltage level. Simultaneous faults in galvanically isolated grids need not be considered.

The neutral or PEN conductor of the low-voltage system can be connected to the earth-termination system of the medium-voltage system if the following conditions are fulfilled in case of an earth fault in the medium-voltage system:

- ➔ No dangerous touch voltage will occur in the low-voltage system or in the consumer's installations connected to it
- ➔ The voltage load on the low-voltage devices in the consumer's installations will not exceed the values defined in IEC 60364-4-41 as a result of the potential rise at the low-voltage neutral point.

The medium-voltage earth-termination system should also be integrated in the lightning protection system.

A layout plan that shows the material, position of the earth electrodes, their branching points and burial depth should be prepared for the earth-termination system.

Earth-termination system for onshore wind turbines

White Paper



Before commissioning, a test report should be created to confirm that all the requirements of the relevant standards have been fulfilled.

The IEC 62305-3 lightning protection standard requires an earth resistance $\leq 10 \Omega$.

Foundation earth electrodes

Foundation earth electrodes make technical and economic sense. In Germany, they must be designed and installed according to DIN 18014.

Foundation earth electrodes are required in the German technical connection conditions (TAB) published by German distribution network operators.

Foundation earth electrodes are a part of the electrical installation (DIN 18014, section 4) and fulfil essential safety functions. Therefore, they must be installed by or under the supervision of an electrician.

Foundation earth electrodes must be installed as a closed ring and arranged in the foundation of the exterior walls of the

building or in the foundation slab according to DIN 18014. They must be covered on all sides by 5 cm of concrete.

Foundation earth electrodes must be made of galvanised or non-galvanised round or strip steel.

➔ Round steel must have a minimum diameter of 10 mm.

➔ Strip steel must have minimum dimensions of 30 mm x 3.5 mm.

The foundation earth electrode must be connected to the main equipotential bonding bar inside the wind turbine by means of a connection component (Figure 1).

According to the IEC 62305-3 lightning protection standard, a foundation earth electrode must feature terminal lugs for connecting the down conductors of the external lightning protection system to the earth-termination system (Figures 1 and 2).

In case of reinforced foundations which are commonly used for wind turbines, round or strip steel is placed on the lower reinforcement layer (Figure 3 to 5). It must be safely connected to the reinforcement at intervals of 2 m in such a way that it

Foundation earth electrode 1

- Round wire (\varnothing 10 mm) or strip (30 mm x 3.5 mm), St/tZn
- Concrete cover of at least 5 cm
- Closed ring
- Connection to the reinforcement at intervals of 2 m by means of a clamp 4

Terminal lug 2 to main earthing busbar 6 and terminal lugs 3 for the earthing system of the tower with SV clamp 5 at least 1.5 m long, easily identifiable

- Round wire, StSt, e.g. mat. No. AISI/ASTM 316 Ti (V4A), 10 mm
- Strip, StSt, e.g. mat. No. AISI/ASTM 316 Ti (V4A), 30 x 3.5 mm
- Round wire, StZn, \varnothing 10 mm, with plastic sheath
- Fixed earthing terminal

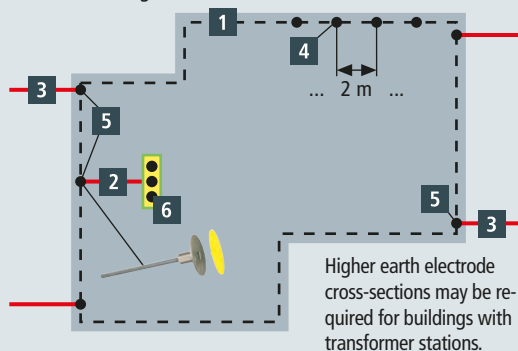

Figure 1 Foundation earth electrode with connection component for the lightning protection system and main equipotential bonding bar

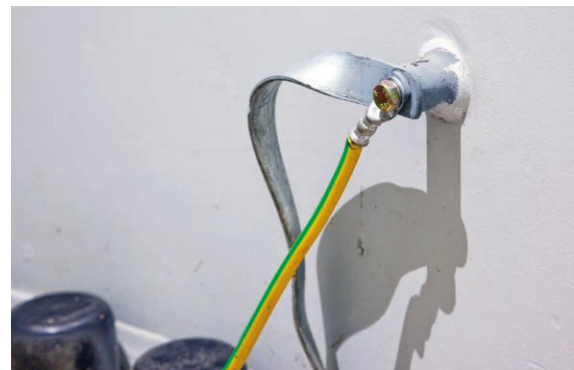

Figure 2 Terminal lug – Connects the earth-termination system of the tower to the earth-termination system



Figure 3 Reinforcement of a wind turbine with foundation earth electrode

Earth-termination system for onshore wind turbines

White Paper

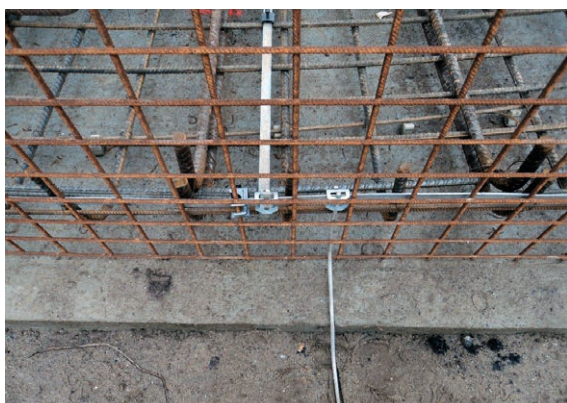

Figure 4 Reinforcement of a wind turbine with clamps

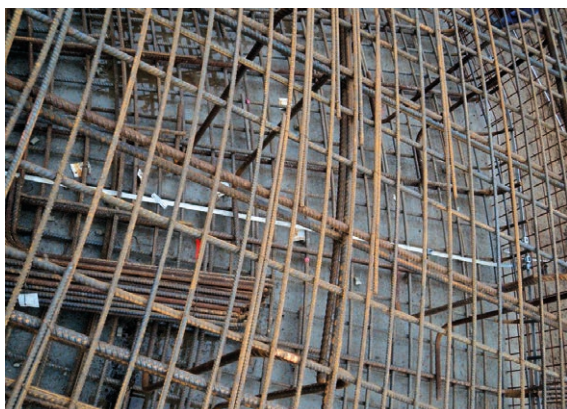

Figure 5 Reinforcement connected to the earth-termination system at intervals of 2 m

is electrically conductive. This is done by welding, clamping or pressing. No wedge connectors must be used if the concrete is compacted mechanically (e.g. by vibrators).

Welding

Welding connections should be made according to ISO 857-1 and DIN 1910-11. Only companies with appropriate verification of their suitability (manufacturer's qualification according to DIN EN ISO 17660-1 or DIN EN ISO 17660-29) may carry out welding work. The welding must be performed by qualified welders. Welded connections with the reinforcement bars require the permission of the civil engineer. The reinforcing bars should be welded together over a length of at least 30 mm.

Lightning protection system

If the foundation earth electrode is used as part of the lightning protection system, connection components according to IEC 62561-1 must be used.



Figure 6 Connection of the earth electrode to the reinforcement



Figure 7 Ring earth electrode connected to the foundation earth electrode

For equipotential bonding in case of lightning protection systems and for EMC purposes, round or strip steel must be installed in the foundation and connected to the reinforcement and the equipotential bonding bar.

In case of a lightning strike, no flashover may occur from the foundation through the insulation system to the earth-termination system. This is achieved in compliance with IEC 62305-3

Earth-termination system for onshore wind turbines

White Paper



Figure 8 Reinforcement of a wind turbine with buried ring earth electrode

with a maximum mesh size of the ring earth electrode of 10 m x 10 m.

The ring earth electrode and the terminal lugs must be corrosion-resistant in design (high-alloy stainless steel (V4A), material number AISI/ASTM 316 Ti).

Documentation

A layout plan is required for the installation of the foundation earth electrode. Photos, plans and test reports serve as documentation.

An example of the documentation for an earth-termination system can be found in Annex A of the German DIN 18014 standard or can be downloaded at: <http://www.dehn.de/de/pruefprotokolle>.

Example: Earth-termination system of a wind turbine

The foundation of the wind turbine is designed as a circular ring with an outer diameter of 21.00 m and an inner diameter of 10.00 m. A foundation earth electrode made of 30 mm x 3.5 mm galvanised strip steel is installed inside the foundation and a ring earth electrode made of 10 mm round steel (stainless steel (V4A), material No. AISI/ASTM 316 Ti) is installed outside the foundation (Figures 7 to 10).

The following requirements apply to the earth-termination system used in the example:

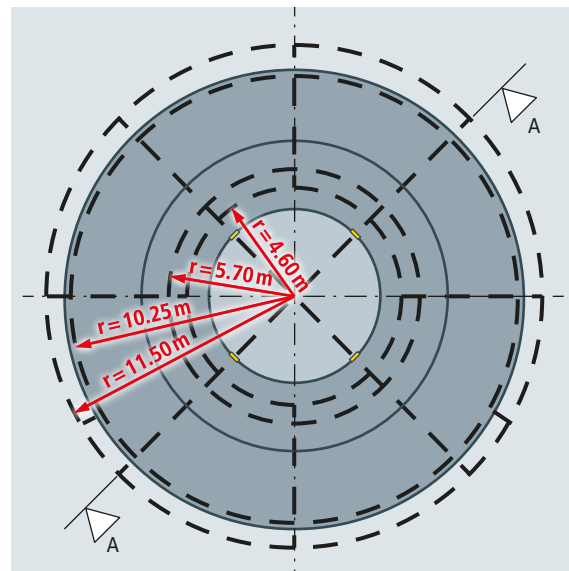

Figure 9 Top view of a foundation

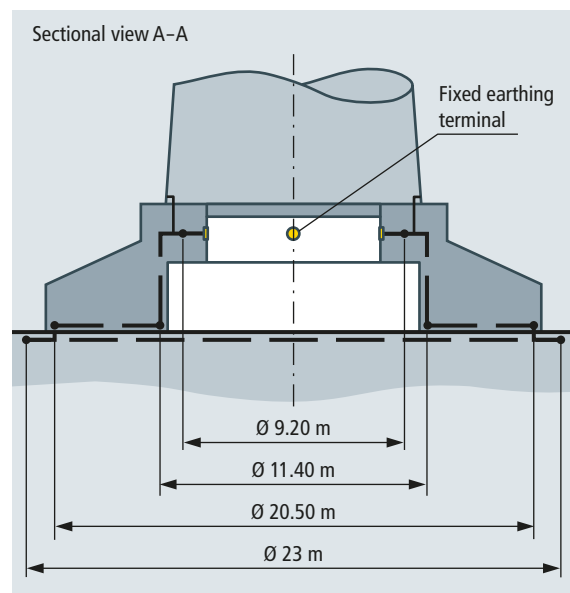

Figure 10 Sectional view of a foundation with earth-termination system

- ➔ A foundation earth electrode consisting of 30 mm x 3.5 mm galvanised strip steel is installed in the foundation with a radius of 10.25 m.
- ➔ The foundation earth electrode is covered by 25 cm of concrete.

Earth-termination system for onshore wind turbines

White Paper



- ➔ An inner ring with a radius of 5.70 m and an additional ring with a radius of 4.60 m are also installed in the foundation.
 - ➔ The galvanised strip steel is clamped to the reinforcement at intervals of 2 m (**Figure 5**).
 - ➔ Three connecting conductors are routed from the foundation earth electrode with a radius of 10.25 m to the inner ring with a radius of 5.70 m and the inner ring with a radius of 4.60 m at an angle of 120° from each other.
 - ➔ The connecting conductors are also clamped to the reinforcement.
 - ➔ Two terminal lugs are connected from the inner ring with a radius of 4.60 m to a fixed earthing terminal (equipotential bonding).
 - ➔ Four terminal lugs are connected from the inner ring with a radius of 4.60 m to the down conductors of the tower.
 - ➔ A ring earth electrode made of round steel (10 mm, stainless steel (V4A), material no. AISI/ASTM 316 Ti) is installed at a distance of 1.0 m from the outer edge of the foundation.
 - ➔ Eight stainless steel (V4A) connecting conductors are routed from the ring earth electrode with a radius of 11.50 m to the inner ring with a radius of 4.60 m and are clamped to the inner ring.
 - ➔ Four of these eight stainless steel (V 4A) connecting conductors are also connected to a cross clamp in the centre of the circle.
 - ➔ Stainless steel (V4A) earth rods can be connected at three points of the ring earth electrode offset at an angle of 120° to one another (optional).
- In addition, the earth-termination system must be connected to the equipotential bonding bar inside the tower.

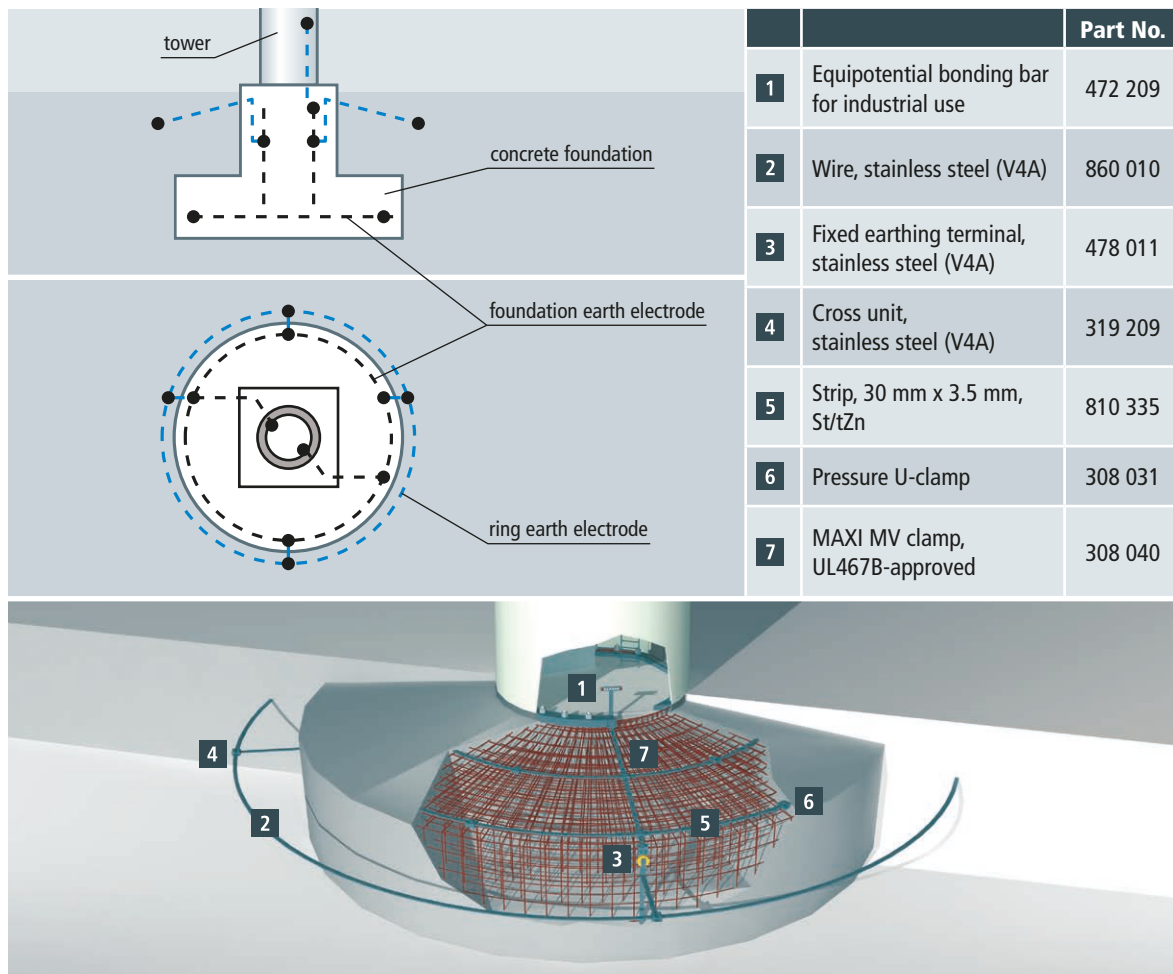

Figure 11 Recommended products for an earth-termination system

Fixed earthing terminals

 **EFPM M10 12 V4A L230 STTZN (478 011)**



Figure without obligation

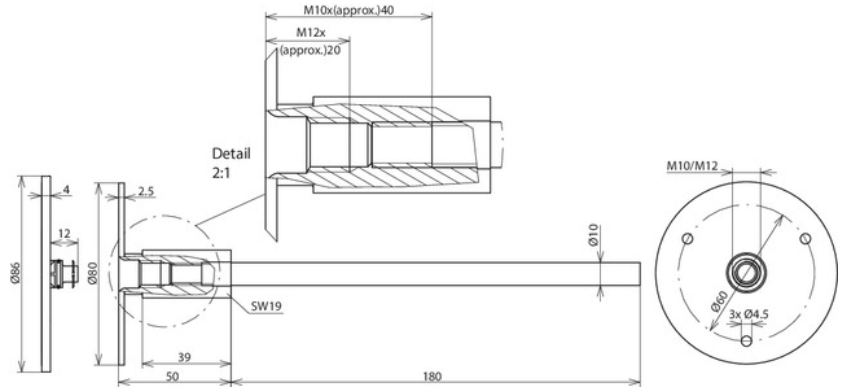

Type	EFPM M10 12 V4A L230 STTZN
Part No.	478 011
Connection thread	M10 / M12
Material of plate	StSt (V4A)
Material No.	1.4571 / 1.4404 / 1.4401
ASTM / AISI:	316Ti / 316L / 316
Material of axis	St/tZn
Connection plate Ø	80 mm
Dimension of connection axis (Ø / length)	10 / 180 mm
Short-circuit current (50 Hz) (1 s; ≤ 300 °C)	6.5 kA
Standard	EN 62561-1
UL approval	UL467
Minimum lengths of screws M10	35 mm (thread length 40 mm)
Minimum lengths of screws M12	15 mm (thread length 20 mm)
Weight	301 g
Customs tariff number (Comb. Nomenclature EU)	85389099
GTIN	4013364033054
PU	10 pc(s)

Equipotential busbar industry



PAS I 6AP M10 V2A (472 209)



Figure without obligation

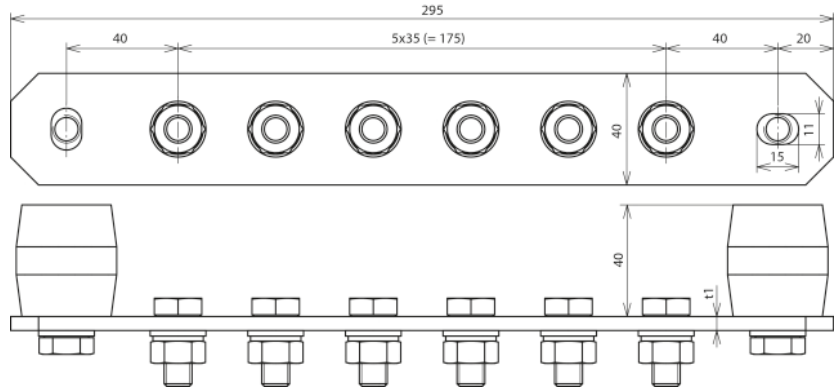

Type	PAS I 6AP M10 V2A
Part No.	472 209
Quantity of terminals	6
Material	StSt
Material No.	1.4301 / 1.4303
Dimension (l x w x d1)	295 x 40 x 6 mm
Cross-section	240 mm ²
Short-circuit current (50 Hz) (1 s; ≤ 300 °C)	8.9 kA
Screw	● M10 x 25 mm
Material of screw / nut	StSt
Design	with spring washer
Material of insulator	UP
Colour of insulator	red ●
Standard	EN 62561-1
Weight	1,01 kg
Customs tariff number (Comb. Nomenclature EU)	85389099
GTIN	4013364090934
PU	1 pc(s)

Connecting clamp for foundation earth electrodes



VK DB 6.20 8.10 FL30 BSB STBL (308 031)

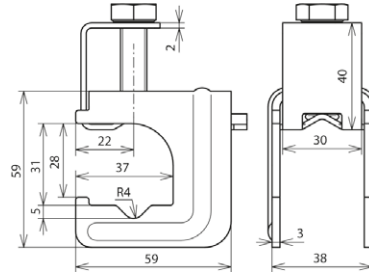

Figure without obligation

Type	VK DB 6.20 8.10 FL30 BSB STBL
Part No.	308 031
Material	St/bare
Clamping range Rd / Rd	(+II) 6-20 / 8-10 mm
Clamping range Rd / FI	(+II) 6-20 / 30 x 3-4 mm
Clamping range FI / FI	(+II) 30 x 3-4 / 30 x 3-4 mm
Screw	● M10 x 35 mm
Material of screw	St/bare
Short-circuit current (50 Hz) (1 s; ≤ 300 °C)	8.4 kA
Standard	EN 62561-1
Weight	230 g
Customs tariff number (Comb. Nomenclature EU)	85389099
GTIN	4013364136571
PU	25 pc(s)

MAXI MV clamp



MAMVK 8.16 15.25 STBL (308 040)

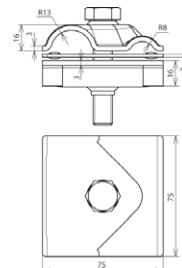

Figure without obligation

Type	MAMVK 8.16 15.25 STBL
Part No.	308 040
Material	St/bare
Clamping range Rd / Rd	(+II) 8-16 / 15-25 mm
Screw	● M12 x 65 mm
Material of screw	St/bare
Short-circuit current (50 Hz) (1 s; ≤ 300 °C)	10.2 kA
Standard	EN 62561-1
UL certification	UL467B
Weight	450 g
Customs tariff number (Comb. Nomenclature EU)	85389099
GTIN	4013364055902
PU	20 pc(s)

Cross unit

KS 8.10 8.10 FL30 ZP V4A (319 209)

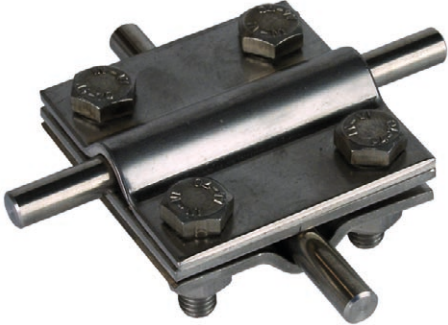
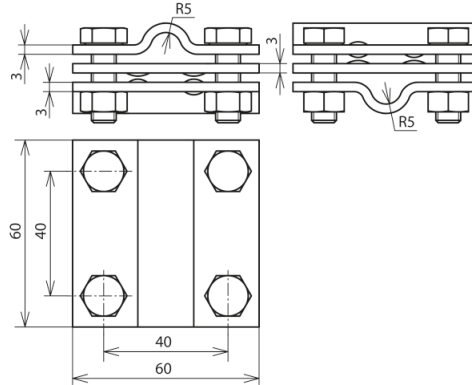



Figure without obligation



Type	KS 8.10 8.10 FL30 ZP V4A
Part No.	319 209
Material of clamp	StSt (V4A)
Clamping range Rd / Rd	8-10 / 8-10 mm
Clamping range Rd / FI	8-10 / 30 mm
Clamping range FI / FI	30 / 30 mm
Clamping range (stranded / cable)	50-70 mm ²
Screw	 M8 x 25 mm
Material of screw / nut	StSt (V4A)
Material No.	1.4571 / 1.4404 / 1.4401
ASTM / AISI:	316Ti / 316L / 316
Dimension	60 x 60 x 3 mm
Intermediate plate	yes
Standard	EN 62561-1
Short-circuit current (50 Hz) (1 s; ≤ 300 °C)	7 kA
Weight	313 g
Customs tariff number (Comb. Nomenclature EU)	85389099
GTIN	4013364035980
PU	25 pc(s)

Flat strip

BA 30X3.5 STTZN R50M (810 335)



Figure without obligation

Steel strip according to EN 62561-2 with zinc coating $\geq 70 \mu\text{m}$ average (about 500 g/m^2), for use in lightning protection and earth-termination systems.

Type Part No.	BA 30X3.5 STTZN R50M 810 335
Width	30 mm
Thickness	3.5 mm
Cross-section	105 mm^2
Material	St/tZn
Standard	EN 62561-2
Zinc coating	$\geq 70 \mu\text{m}$ average (about 500 g/m^2)
Conductivity	$\geq 6.66 \text{ m} / \text{Ohm mm}^2$
Resistivity	$\leq 0.15 \text{ Ohm mm}^2 / \text{m}$
Short-circuit current (50 Hz) (1 s; $\leq 300 \text{ }^\circ\text{C}$)	7.3 kA
Weight	840 g/m
Customs tariff number (Comb. Nomenclature EU)	72123000
GTIN	4013364032880
PU	50 m

Round wire

RD 10 V4A R80M (860 010)



Figure without obligation

Stainless steel wire according to EN 62561-2, for use in lightning protection and earth-termination systems or equipotential bonding.

Stainless steel wire for use in soil has to be made of StSt (V4A) with a molybdenum proportion $> 2 \%$ e.g. 1.4571, 1.4404, in accordance with EN 62561-2 and IEC/EN 62305-3.

Type Part No.	RD 10 V4A R80M 860 010
Diameter \varnothing conductor	10 mm
Cross-section	78 mm^2
Material	StSt (V4A)
Material No.	1.4571 / 1.4404
ASTM / AISI:	316Ti / 316L
Standard	based on EN 62561-2
Conductivity	$\geq 1.25 \text{ m} / \text{Ohm mm}^2$
Resistivity	$\leq 0.8 \text{ Ohm mm}^2 / \text{m}$
Short-circuit current (50 Hz) (1 s; $\leq 300 \text{ }^\circ\text{C}$)	2.9 kA
Weight	617 g/m
Customs tariff number (Comb. Nomenclature EU)	72210010
GTIN	4013364019997
PU	80 m

www.dehn-international.com/partners



Surge Protection
Lightning Protection
Safety Equipment
DEHN protects.

DEHN + SÖHNE
GmbH + Co.KG.

Hans-Dehn-Str. 1
Postfach 1640
92306 Neumarkt
Germany

Tel. +49 9181 906-0
Fax +49 9181 906-1100
info@dehn.de
www.dehn-international.com



www.dehn-international.com/partners

Type designations of products mentioned in this white paper which are at the same time registered trademarks are not especially marked. Hence the absence of TM or © markings does not indicate that the type designation is a free trade name. Nor can it be seen whether patents or utility models and other intellectual and industrial property rights exist. We reserve the right to introduce changes in performance, configuration and technology, dimensions, weights and materials in the course of technical progress. The figures are shown without obligation. Misprints, errors and modifications excepted. Reproduction in any form whatsoever is forbidden without our authorisation.

For information on our registered trademarks, please visit de.hn/tm.